

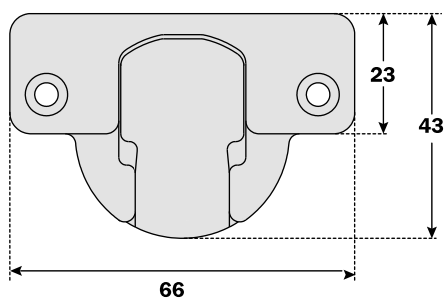

**Serie F**  
***SALICE***

**Per ante sagomate e di forte spessore.  
Ala in zama, scatola in acciaio.  
Dimensione scatola ø 40 mm.**



Valore costante "L" 0.7 mm; non cambia regolando lateralmente la cerniera.

Numero indicativo delle cerniere occorrenti in funzione della dimensione e del peso dell'anta.

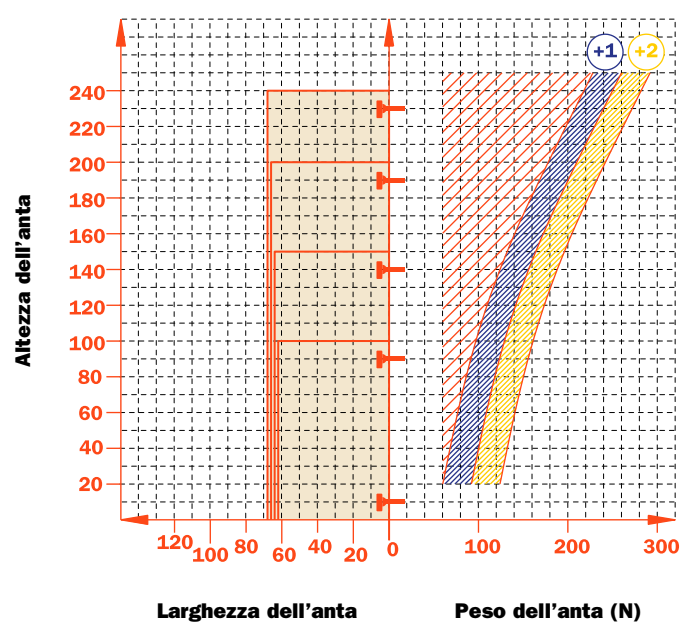

## Regolazioni

Regolazione laterale compensata da -0.5 a +5.5 mm.  
Regolazione verticale  $\pm 2$  mm.  
Regolazione frontale con basi Serie 200 +2.8 mm.  
Regolazione frontale con basi Domi da -0.5 a +2.8 mm.

## Basi

Basi simmetriche e asimmetriche in acciaio o in zama nichelato opaco della Serie 200.  
Innesto rapido su basi Domi.  
Posizionamento con fine corsa prestabilito su basi tradizionali Serie 200.

N.B. : Utilizzare un cacciavite POZIDRIVE n°2 per tutte le viti.

	<p>52  <math>\phi 40</math>          7.5  <math>94^\circ</math>          K</p>
<b>Vite legno</b>	<p><b>A</b></p>

	<p>52  <math>\phi 40</math>  <math>\phi 10</math>          7.5  <math>94^\circ</math>          K</p>
<b>Codolo</b>	<p><b>B</b></p>

**Utilizzare le tabelle per identificare le forature e i fissaggi disponibili. Inserire nella terza posizione del codice della cerniera la lettera o il numero corrispondente alla scelta fatta. Esempio: CF\_7A99.**

↑  
 Inserire in questa posizione la lettera o il numero selezionati.

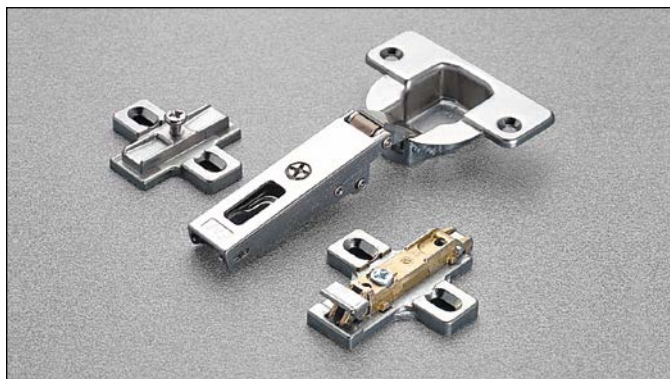

## Informazioni tecniche

**Per ante sagomate e di forte spessore, massimo 40 mm.**

Profondità della scatola in acciaio 13 mm.

Diametro della scatola 40 mm.

Apertura 94°.

Possibilità di foratura dell'anta "K" da 3 a 15 mm.

Adattabili a tutte le basi tradizionali Serie 200 e a tutte le basi Domi a innesto rapido.

## Spazio occorrente per l'apertura dell'anta

	T=	20	21	22	23	24	25	26	27	28	29	30	31	32	33	34	35	36	37	38	39	40	L=
K=3	A=	0.4	0.5	0.7	0.8	1.0	1.2	1.4	1.6	1.9	2.2	2.5	2.8	3.1	3.5	4.1	5.0	6.0	6.9	7.8	8.8	9.7	0.0
K=4	A=	0.4	0.5	0.7	0.8	1.0	1.2	1.4	1.6	1.9	2.1	2.4	2.7	3.0	3.4	3.8	4.4	5.3	6.3	7.2	8.1	9.0	0.0
K=5	A=	0.4	0.5	0.6	0.8	1.0	1.2	1.4	1.6	1.8	2.1	2.4	2.7	3.0	3.3	3.7	4.1	4.8	5.7	6.6	7.5	8.4	0.0
K=6	A=	0.4	0.5	0.6	0.8	0.9	1.1	1.3	1.6	1.8	2.1	2.3	2.6	2.9	3.3	3.6	4.0	4.4	5.2	6.0	6.9	7.8	0.0
K=7	A=	0.4	0.5	0.6	0.8	0.9	1.1	1.3	1.5	1.8	2.0	2.3	2.6	2.9	3.2	3.6	3.9	4.3	4.8	5.5	6.4	7.3	0.0
K=8	A=	0.4	0.5	0.6	0.8	0.9	1.1	1.3	1.5	1.7	2.0	2.2	2.5	2.8	3.1	3.5	3.8	4.2	4.7	5.1	5.9	6.8	0.0
K=9	A=	0.4	0.5	0.6	0.7	0.9	1.1	1.3	1.5	1.7	2.0	2.2	2.5	2.8	3.1	3.4	3.8	4.2	4.6	5.0	5.5	6.3	0.0
K=10	A=	0.3	0.5	0.6	0.7	0.9	1.1	1.3	1.5	1.7	1.9	2.2	2.4	2.7	3.0	3.4	3.7	4.1	4.5	4.9	5.4	6.0	0.0
K=11	A=	0.3	0.4	0.6	0.7	0.9	1.0	1.2	1.4	1.7	1.9	2.1	2.4	2.7	3.0	3.3	3.6	4.0	4.4	4.8	5.2	5.7	0.0
K=12	A=	0.3	0.4	0.6	0.7	0.9	1.0	1.2	1.4	1.6	1.9	2.1	2.4	2.6	2.9	3.3	3.6	3.9	4.3	4.7	5.1	5.6	0.4
K=13	A=	0.3	0.4	0.5	0.7	0.9	1.0	1.2	1.4	1.6	1.8	2.1	2.3	2.6	2.9	3.2	3.5	3.8	4.2	4.5	4.9	5.4	1.2
K=14	A=	0.3	0.4	0.5	0.7	0.8	1.0	1.2	1.4	1.6	1.8	2.0	2.3	2.6	2.8	3.2	3.5	3.8	4.2	4.5	4.9	5.4	2.2
K=15	A=	0.3	0.4	0.5	0.7	0.8	1.0	1.2	1.4	1.6	1.8	2.0	2.3	2.6	2.8	3.2	3.5	3.8	4.2	4.5	4.9	5.4	3.2

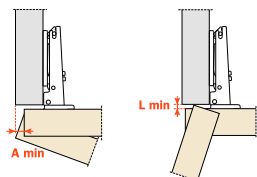

Un'opportuna sagomatura dell'anta diminuisce i valori di "A" e di "L"

## Rientro dell'anta

Rientro dell'anta rispetto al fianco in posizione di massima apertura. Il valore indicato è rilevato con cerniera collo 0, altezza base H=0 e valore K=3.

## Il contenimento

Con questa formula potete ottenere lo spessore massimo dell'anta sagomata apribile senza interferire con fianchi, ante o pareti adiacenti. È sempre da tener presente anche la tabella dei valori L - K - T.

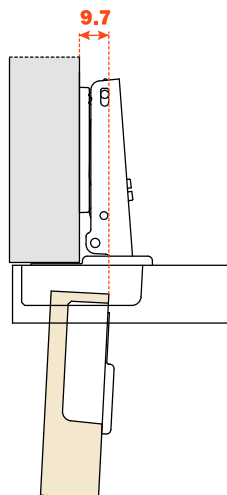

$$C = 28.5 + K + A$$

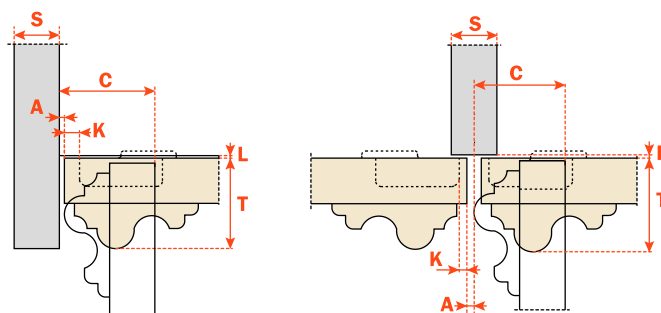

**Imballi**

Scatole 300 pezzi  
 Pallet 7.200 pezzi

**CA** Chiusura automatica**CL** Chiusura libera

Utilizzare queste formule per stabilire il tipo di ala della cerniera, la foratura dell'anta "K" e l'altezza di base "H" necessarie per risolvere ogni problema applicativo.

Utilizzare le tabelle di "foratura e fissaggio" a pagina 3 per completare il codice cerniera desiderato.

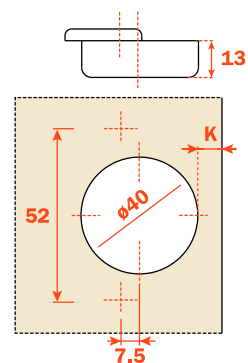
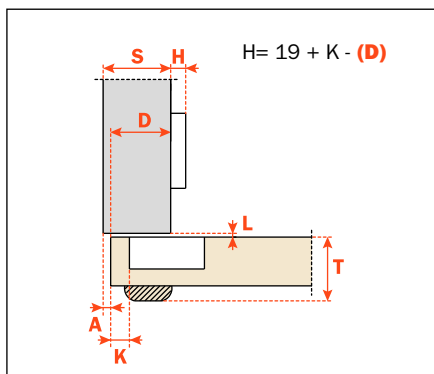
**Collo 0**

**CA - CF\_7A99**  
**CL - CF\_5A99**

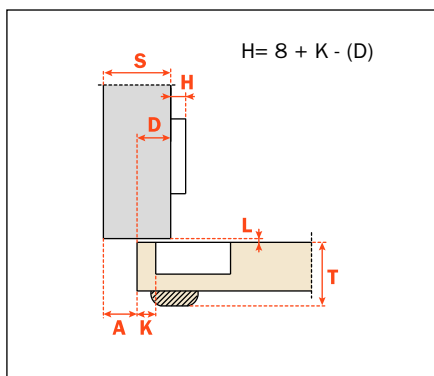
**Collo 11**

**CA - CF\_7G99**  
**CL - CF\_5G99**

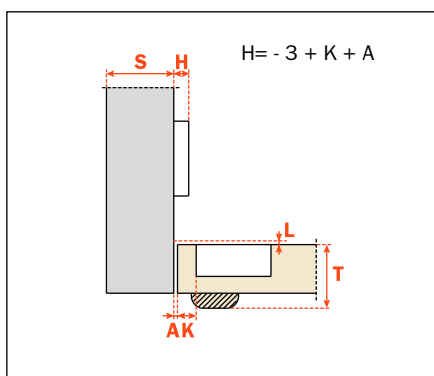
**Collo 22**

**CA - CF\_7P99**  
**CL - CF\_5P99**

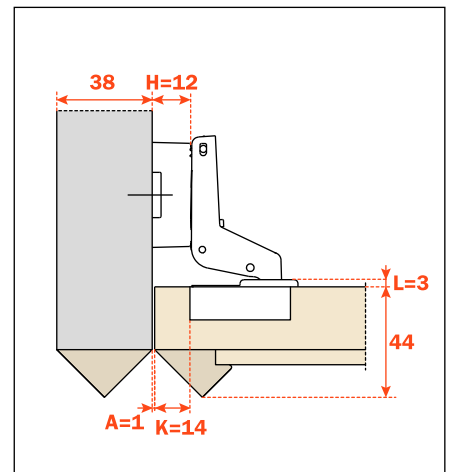
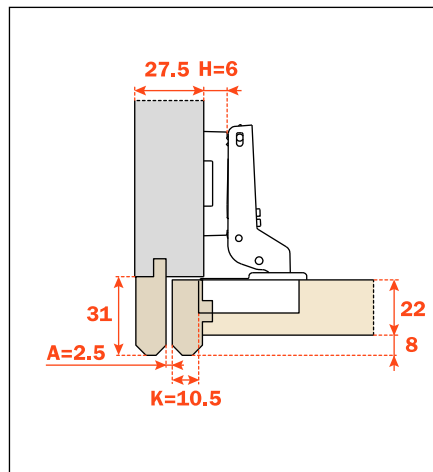
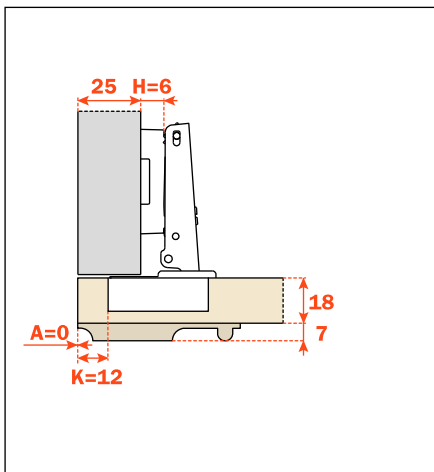
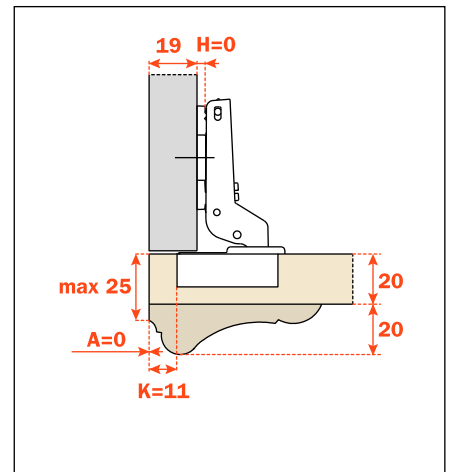
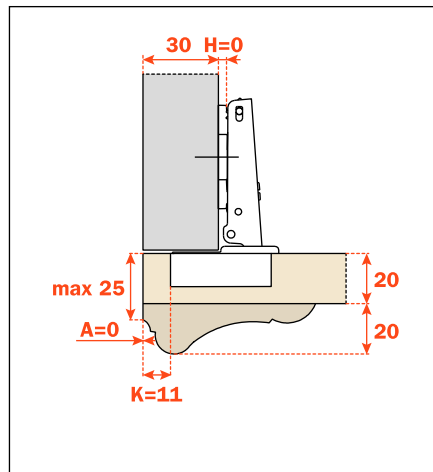
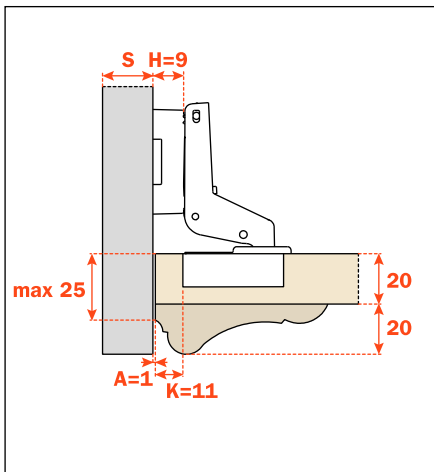
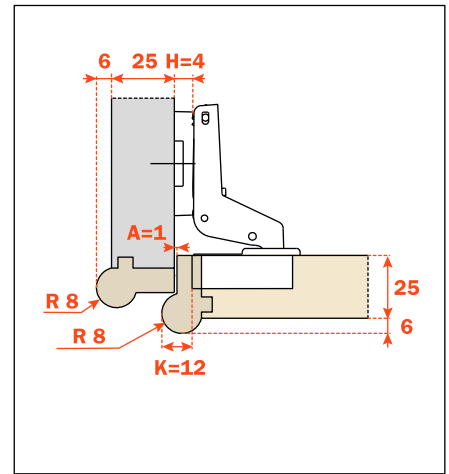
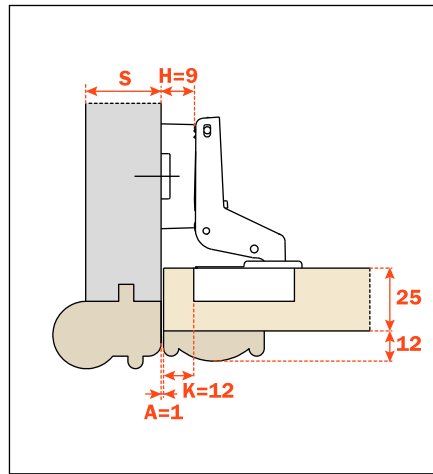
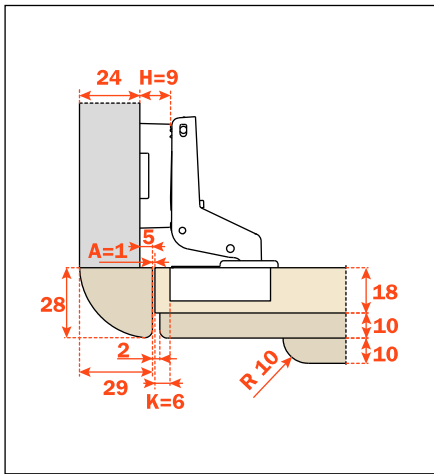
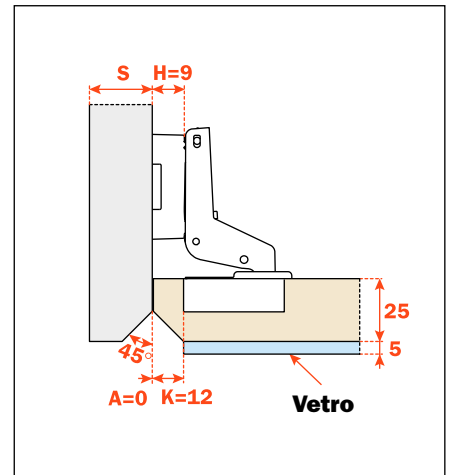
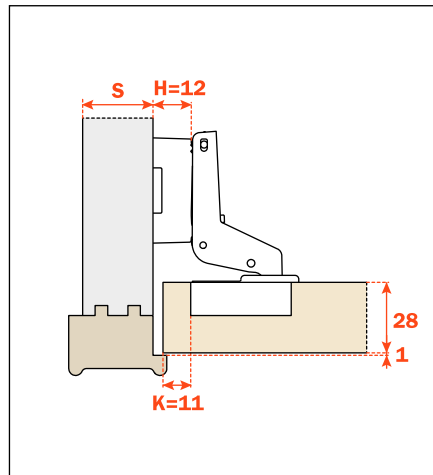
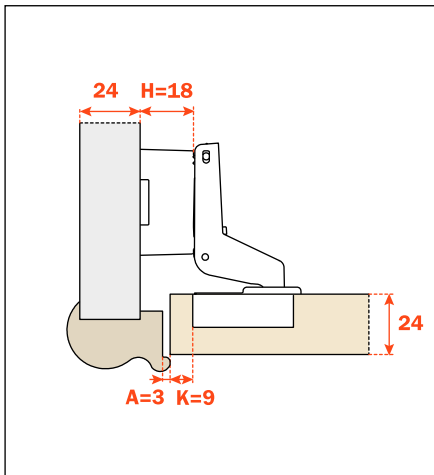

Lined writing area consisting of horizontal lines for text entry.

**DEUTSCHE SALICE GMBH**

RUDOLF DIESEL STR. 10  
POSTFACH 1154  
74382 NECKARWESTHEIM  
TEL. 07233 9807-0  
FAX. 07233 9807-16  
info.salice@deutschesalice.de  
www.deutschesalice.de

**DEUTSCHE SALICE GMBH**

VERKAUFSBÜRO NORD  
RINGSTRASSE 36/A30 CENTER  
32584 LÖHNE  
TEL. 05731 15608-0  
FAX. 05731 15608-10  
vknord@deutschesalice.de  
www.deutschesalice.de

**SALICE FRANCE S.A.R.L.**

ROUTE DE GOA ZAC LES 3 MOULINS  
06600 ANTIBES  
TEL. 0493 330069  
FAX. 0493 330141  
info.salice@salicefrance.com  
www.salicefrance.com

**SALICE ESPAÑA, S.L.U.**

CALLE COPÉRNICO, 11  
POLÍGONO INDUSTRIAL  
COLL DE LA MANYA  
08403 GRANOLLERS (BARCELONA)  
TEL. 938 46 88 61  
FAX 938 49 11 97  
info.salice@saliceespana.es  
www.saliceespana.es

**SALICE UK LTD.**

KINGFISHER WAY  
HINCHINGBROOKE BUSINESS PARK  
HUNTINGDON CAMBS PE 29 6FN  
TEL. 01480 413831  
FAX. 01480 451489  
info.salice@saliceuk.co.uk  
www.saliceuk.co.uk

**SALICE AMERICA INC.**

2123 CROWN CENTRE DRIVE  
CHARLOTTE NC. 28227  
TEL. 704 8417810  
FAX. 704 8417808  
info.salice@saliceamerica.com  
www.saliceamerica.com

**SALICE CANADA INC.**

3500 RIDGEWAY DRIVE,  
UNIT#1  
MISSISSAUGA, ONTARIO, L5L 0B4  
TEL. 905 8208787  
FAX. 905 8207226  
info.salice@salicecanada.com  
www.salicecanada.com

**SALICE CHINA  
(SHANGHAI) CO. LTD.**

1st FLOOR, B1 BLDG 928 MINGZHU ROAD  
XUJING, QINGPU DISTRICT  
SHANGHAI 201702 - CHINA  
Tel. 021 3988 9880  
Fax 021 3988 9882  
info.salice@salicechina.com  
www.salicechina.com